

PROJECT NAME:

DATE:

LOCATION:

AIA #:

MANUFACTURER REPRESENTATIVE:

ITEM # / QUANTITY:

DRYAGER™ UX 1500 PRO

FOR UP TO 220 lbs

Quality from
Germany



Professional refrigerated full height single section dry aging cabinet for commercial production of **dry-aged meat, charcuterie, fish** as well as for producing and storing of **cheese** in foodservice, hospitality, retail and food processing industries. **Self-contained R600a refrigeration** (115V - 2A) maintains perfect microclimate with electronic temperature (32-77°F) and humidity (60-90%) control for minimal product loss **without the requirement for water connection or drain**. Unique UX-Aireg **UV sterilization system** maintains internal air quality and flow without UV exposure of the product. Stainless steel exterior and antibacterial polystyrene interior with integral rack slides and stainless steel back cover. Cabinet designed for **built-in or free-standing application** for single section or multi-unit integration. Two years parts and labor warranty – five years compressor warranty.



STANDARD FEATURES

Temperature & Humidity

- Humicontrol™ – steady humidity electronically controlled from 60 % to 90 % without the requirement for water connection or drain
- Electronically controlled temperature from 32 °F to 77 °F (0 °C to +25 °C)
- Superior aging with minimal weight loss
- Automatic defrost and automatic condensation evaporation

Hygiene

- UVC sterilization system UX Aireg™ – optimal airflow & air quality without UV exposure of the product
- Antibacterial interior with molded slides and coved corners

Visual design

- Stainless steel exterior and door frame
- Dimmable LED lighting – perfect lighting of displayed products
- Maximum visual appeal & merchandising potential

Safety

- UV protection through tinted double pane glass door
- Visual & audible alarm
- Lockable door and snap-in magnetic gasket

Modularity

- Cabinet designed for free-standing or built in application for single section or multiple units
- Door hinges reversible

Included accessories: XL accessory package

- 4 x Full shelf (DUS020) - stainless steel, max. load/shelf 88 lbs
- 1 x Double hanger (DU0010) - stainless steel, max. load 176 lbs
- 1 x SALTAIR tray (DU0070) - stainless steel
- 4 x Swivel hook - stainless steel, max. load/hook 220 lbs

Warranty

- Compressor: 5 years, parts & labor: 2 years



Conformity

UL 60335-1: 2016
 UL 60335-2-89: 2017
 CAN/CSA-C22.2 No. 60335-1:16
 CAN/CSA-C22.2 No. 60335-2-89:17
 NSF/ANSI 7: 2016



TECHNICAL SPECIFICATIONS

Internal capacity/net	17.0/15.3cu. ft. (482/432 liters)
Maximum load	220 lbs (100 kg)
Internal Dimensions HxWxD	53.98 x 22.76 x 23.11 in
External Dimensions HxWxD	64.96 x 27.56 x 29.21 in
Temperature range	0 °C to +25 °C (32 °F to 77 °F)
Humicontrol™	60 % to 90 %
Connection rating	115 V / 2 A / 60 Hz
NEMA plug configuration	5-15P
Average energy consumption	~ 1.6 kWh/24h
UVC sterilisation system	Yes
Water and drain connection required	No
Automatic defrost	Yes
Automatic condensation evaporation	Yes

LED interior lighting dimmable	Yes
External housing finish	Stainless steel
Door material	Stainless steel & metallic tinted glass (UV protect)
Door reversible & lockable	Yes
Magnetic door seal, exchangeable	Yes
Door handle	Robust
Alarm	Visual & acoustic
Installation	Integration & free standing
Ambient temperature	10 °C to 30 °C (50 °F to 86 °F)
Refrigerant	R600a
Empty weight	194 lbs
Shipping weight	241 lbs
Shipping dimensions HxWxD	67.32 x 29.92 x 32.28 in

DRYAGER™ UX 1500 PRO

FOR UP TO 220 lbs

USE CASES: LOADING WITH MEAT



Beef on shelves



Two saddles of beef hanging



Saddles of beef and pork hanging



Beef on shelves and pork hanging below

MORE USE CASES: ONE DRYAGER™ DIFFERENT APPLICATIONS



Charcuterie production: Sausage and ham | Dry Aging of meat*



Dry Aging of fish and seafood | Dry Aging of meat*



Dry Aging of poultry and meat | storing and production of cheese*



Tempering champagne and wine | production and storing of cheese*

*Shelves in pictures differ from UX 1500 PRO shelves.

DRYAGER™ UX 1500 PRO

FOR UP TO 220 lbs

DRAWINGS

Front view

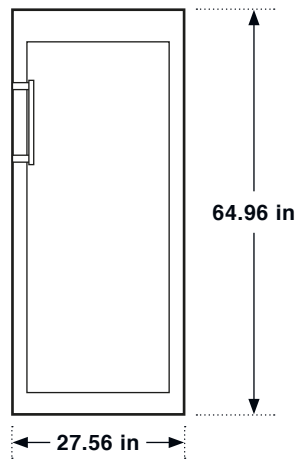

Top view

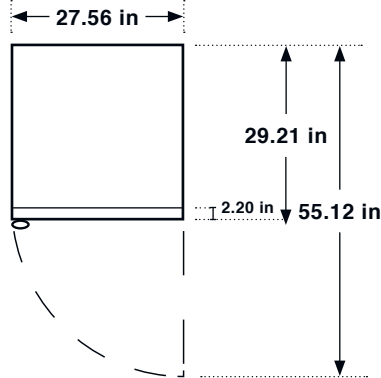

Integration drawing

Single unit integration

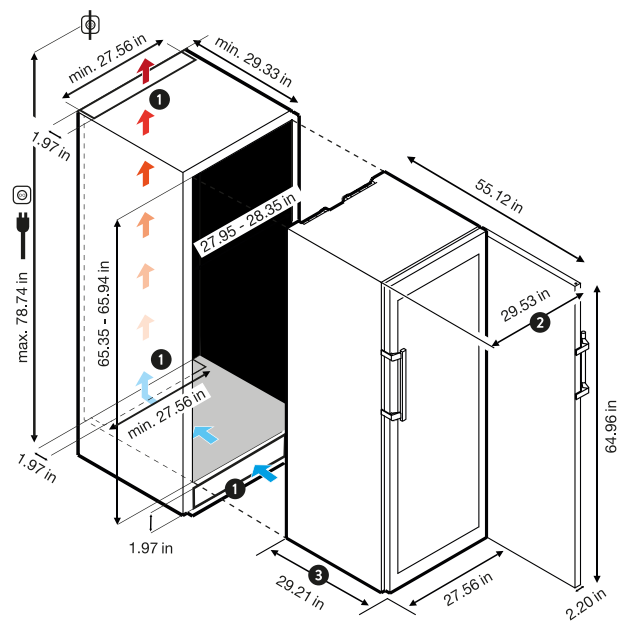

Side by Side integration

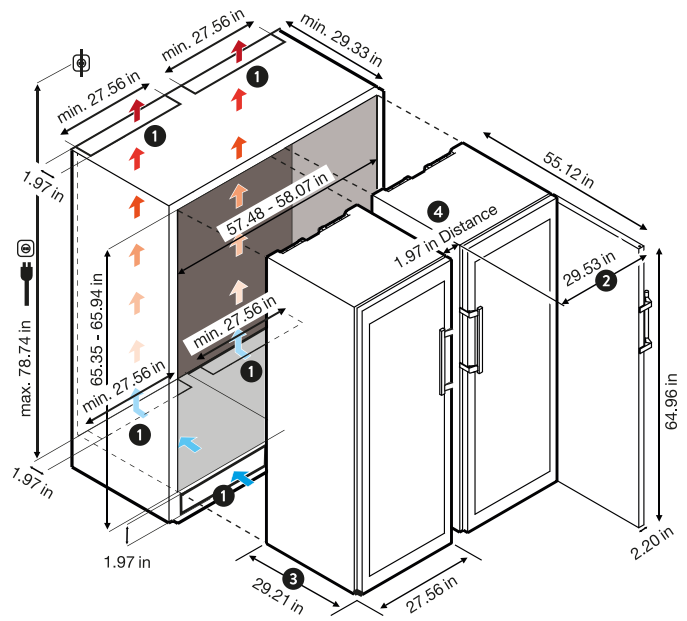

• It is absolutely essential to have good air circulation around the unit. The width of the ventilation shafts needs to be at least the width of the appliance (see ❶). The minimum required depth/height of the shafts is **1.97 in**. Also ensure that the back of the appliance is positioned at a distance of at least 1.97 in from the wall.

• Overall dimension with opened door (see ❷): **29.53 in**.

• Overall dimension body + door (protruding) (see ❸): **29.21 in**.

• Covering of distance (see ❹) possible by DRYAGER™ moulding, available as an accessory at: shop.dry-ager.com.

DRYAGER™ UX 1500 PRO

FOR UP TO 220 lbs

OPTIONAL ACCESSORIES FOR UX 1500 PRO

Single Accessories

- DU0005 Stainless Steel Moulding**
for side-by-side integration installation of two UX 1500 PRO units at a distance of 1.97 in.
- DU0010 Double Hanger**
stainless steel, for hanging up to 4 saddles of meat, total load capacity: 176 lbs, hooks not included
- DUS015 Half Shelf**
stainless steel, for loading over half depth of unit, insertable at many different heights (integral rack slides), load capacity per shelf: 44 lbs
- DUS020 Full Shelf**
stainless steel, for loading over full depth of unit, insertable at many different heights (integral rack slides), load capacity per shelf: 88 lbs
- DUS022 Charcuterie Shelf**
special designed stainless steel shelf for hanging of sausages, salami and ham over half depth of unit, insertable at many different heights (integral rack slides), load capacity per shelf: 44 lbs
- DU0055 SALTAIR Salt-Block Set**
4 pieces of natural crystal salt for optimal support of the humidity regulation, use with DRYAGER™ stainless steel tray (DU0070)
- DU0070 SALTAIR Tray**
high quality stainless steel tray to hold one DRYAGER™ salt-block set (DU0055, not included)
- DU0080 Podium**
perfect presentation of free-standing UX 1500 PRO unit at the eye level, made of sturdy metal, metallic black powder-coating, height adjustable (16.5-17.5 in), including DRYAGER™ logo, optional with wheels (DU0082)
- DU0190 S-Hooks Set**
10 hooks from high quality stainless steel for usage with DRYAGER™ hangers, size 6.3 x 0.3 in, load capacity per hook: 220 lbs
- DU0195 Swivel Hooks Set**
10 swivel hooks from high quality stainless steel, for usage with DRYAGER™ hangers, size 7.1 x 0.3 in, load capacity per hook: 220 lbs

Packages

- DU0130 DRYAGER™ SPECIAL CLEANER Package**
Set of **two** NSF listed cleaners to remove fat, oil, protein residues etc., 16.9 oz (500 ml) spray bottle
- DU0140 XL Meat Label Package**
40 stainless steel skewers with DRYAGER™ designed labels made of reusable plastic
- DU1555 Taste & Operation Package**
1 x SALTAIR salt-block set (DU0058), 1 x XL meat label package (DU0140), 1 x DRYAGER™ SPECIAL CLEANER package (DU0130)
- DU1560 Charcuterie & Flexibility Package**
3 x charcuterie shelf (DUS022), 3 x half shelf (DUS015)

Maintenance

- DU0115 UVC Bulb Replacement Kit**
replacement bulb for annual maintenance of UVC sterilization system
- DUW150 Warranty Extension**
3 years parts and labor, 7 years compressor

