



A WORLD OF SLICERS &  
FOOD PREPARATION MACHINES



2026



Rheninghaus, historic Italian company known internationally for the production of high-end professional and household slicers.

**Choosing our brand means entering a reality of passion, style and quality known all over the world.**

- ✓ **100% Italian professional style**
- ✓ **High quality materials**
- ✓ **Slicers easy to use and clean**
- ✓ **Guarantee of total safety of use**
- ✓ **Worldwide support and assistance**

Wide range of slicers, designed to meet the needs of restaurants, delicatessens and kitchen professionals. Rheninghaus slicers combine precision, efficiency and safety, ensuring perfect slices of cured meats, cheeses and other foods.

Made with high-quality materials and cutting-edge technologies, they are suitable for all types of use, from professional to domestic.

Discover how Rheninghaus slicers can improve your culinary experience, making each dish a work of art!

### Slicer Selection Guide

#### CHOOSE THE RIGHT SLICER FOR YOUR OPERATION!

Here is a practical guide Rheninghaus has created to help you purchase the slicer you need.

Just answer three questions:

1. How long will the slicer be used each day?
2. How to choose the perfect slicer?
3. Can it be used for frozen products?

1. If the slicer is a major player in your daily business, ST and MO models can withstand constant use and are recommended for their cutting precision, powerful performance, and long-lasting reliability.
2. The choice of the slicer depends first of all on the product you want to slice and from the space available. The blades range from 250 to 350 mm in diameter. Increasing the size of the blade allows to increase the size of the product to be sliced. Gravity slicers are very versatile for cutting different types of products. Special food chute for meat and cold cuts and accessories for cutting vegetables are available. Specific blades and configurations are recommended for cheese, bread and fish.
3. For slicing frozen products, Rheninghaus offers the optional serrated blade for all slicers. This makes slicing frozen meats effortless.

### AVAILABLE



MBR  
Manual Blade  
Removal tool



SBR  
Safe Blade  
Removal tool

	Model	Time slicing	Manual (Slice to Order)	Auto (Bulk Slicing)	Motor Power Hp	Blade mm/in	Slice Thickness mm/in	Cutting cross section mm/in
<b>LIGHT DUTY</b>	<b>RTS 10</b>	all day	✓		1/3	250 / 10"	0 - 15 0-9/16"	230x190 9,05x7,48
<b>MEDIUM DUTY</b>	<b>RTS 12</b>	all day	✓		1/2	300 / 12"	0 - 15 0-9/16"	230x210 9,05x8,26"
<b>HEAVY DUTY</b>	<b>ST/SST 12</b>	all day	✓		1/2	300 / 12"	0 - 20 0-1/2"	240x160 9,44x6,29"
	<b>ST/SST 14</b>	all day	✓		1/2	350 / 14"	0 - 20 0-1/2"	280x190 11,02x7,48"
	<b>STA 12</b>	all day	✓	✓	1/2	300 / 12"	0 - 20 0-1/2"	285x165 11,22x6,49"
	<b>MO 12</b>	all day	✓		1/2	300 / 12"	0 - 30 0-1 <sup>3</sup> / <sub>16</sub> "	290x140 11,41x5,51
	<b>MO 14</b>	all day	✓		1/2	350 / 14"	0 - 30 0-1 <sup>3</sup> / <sub>16</sub> "	290x190 11,41x7,48



BELT DRIVEN

**YOUR VERSATILE SLICER**

**IDEAL FOR RESTAURANTS AND BARS**



**RTS 10**  
PROFESSIONAL GRAVITY SLICER – MANUAL BELT DRIVEN

Model	Blade	Cutting cross section	Food chute	Chute stroke	Footprint	Overall dimensions	Net weight	Motor
	mm / in	mm / in	mm / in	mm / in	mm / in	mm / in	Kg	Hp
<b>RTS 10</b>	250 / 10	230x190 9,05x7,48	230x250 9.05x9.84	250 10	A 475/18,70 B 340/13,38 H 400/15,74	A 580/22,83 B 470/18.50 H 400/15.74	19	1/3

Cord & Plug: Attached 5.5 foot exible 3-wire cord with molded plug ts a grounded receptacle. NEMA 5-15  
Voltage: 115 - 60 - 1



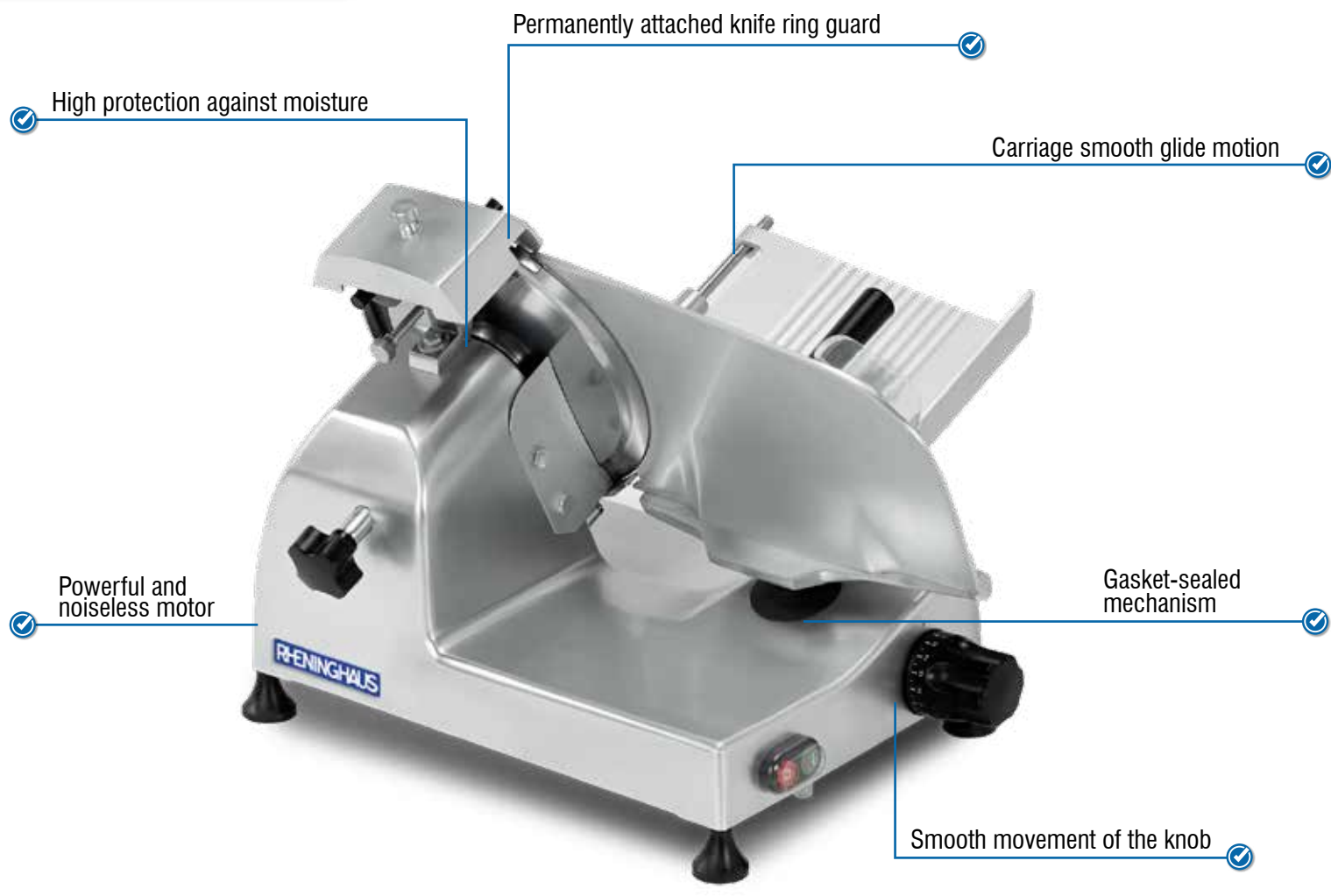

**PERFECT FOR SLICING COLD CUTS, MEAT, VEGETABLES, CHEESES**

- Manual slicer with smooth lines.  
 The rounded base gives a harmonious style to the whole machine.
- 10" hard chromed special alloy hollow ground knife: long-lasting and easy to sharpen
  - 0 to 9/16" slice thickness
  - Knife ring guard
  - Easily accessible, top-mounted, removable all metal knife sharpener with two stones and dual action
  - Gasket-sealed mechanism allows for precision in slice thickness adjustment
  - Drip deflecting edge of the gauge plate ensures adjustment mechanism is protected
  - Bottom enclosure
  - Moisture proof, easy-to-clean ON/OFF switch and knife hub
  - 1/2 HP fan-cooled knife motor with permanently lubricated ball bearings
  - Overload protection manual reset
  - Rounded lines make it easy to clean
  - Non-slip rubber feet add stability and grip.
  - Optional MBR (Manual Blade Removal tool)



BELT DRIVEN

**YOUR VERSATILE SLICER**

**IDEAL FOR RESTAURANTS AND BARS**



**RTS 12**  
PROFESSIONAL GRAVITY SLICER – MANUAL BELT DRIVEN

Model	Blade	Cutting cross section	Food chute	Chute stroke	Footprint	Overall dimensions	Net weight	Motor
	mm / in	mm / in	mm / in	mm / in	mm / in	mm / in	Kg	Hp
<b>RTS 12</b>	300 / 12	230x210 9,05x8,26	260x270 10,23x10,62	260 10,23	A 475/18,70 B 340/13,38 H 420/16,53	A 580/22,83 B 480/18,89 H 420/16,53	21	1/2

Cord & Plug: Attached 5.5 foot exible 3-wire cord with molded plug ts a grounded receptacle. NEMA 5-15  
Voltage: 115 - 60 - 1



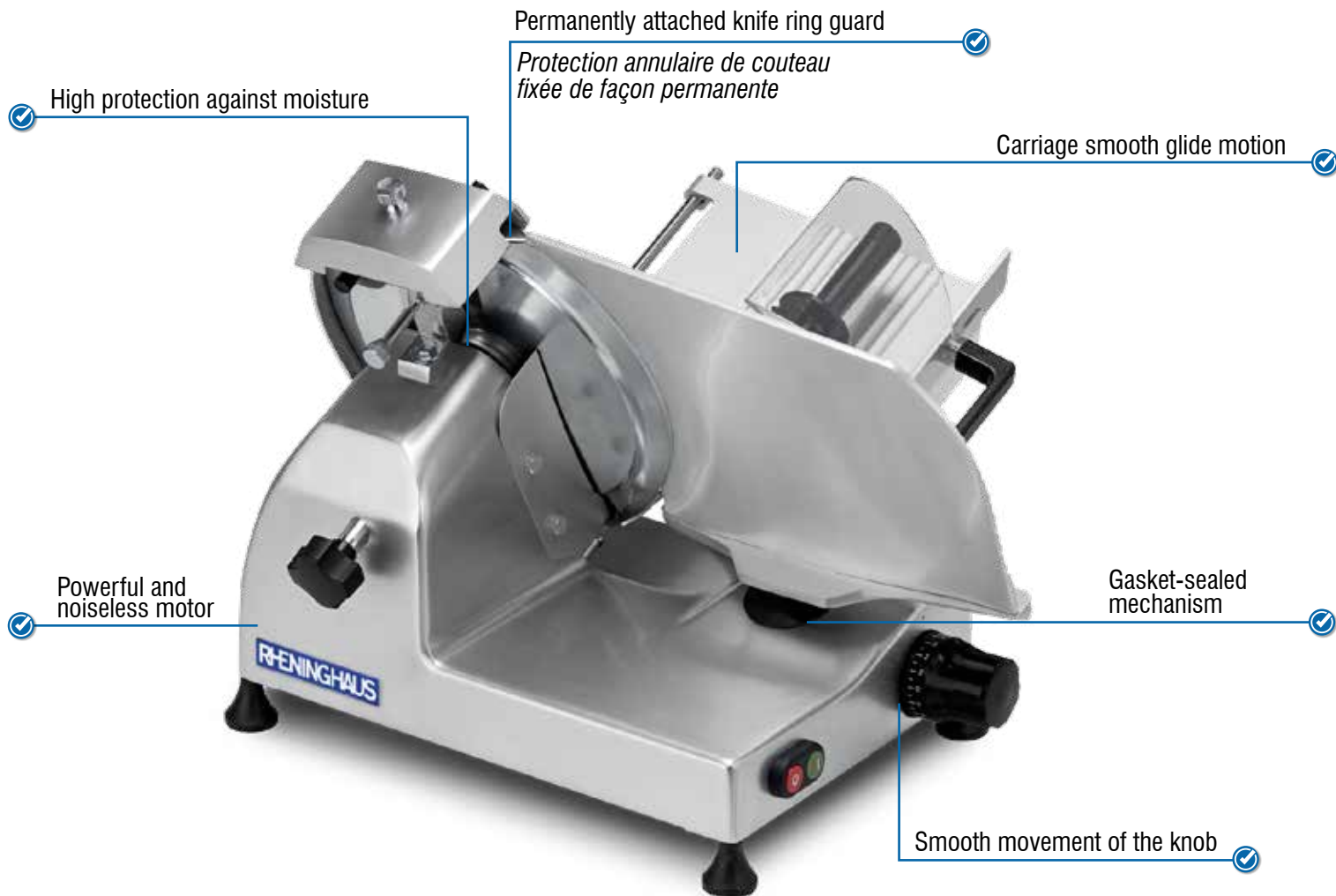

**PERFECT FOR SLICING COLD CUTS, MEAT, VEGETABLES, CHEESES**

Manual slicer with smooth lines.

The rounded base gives a harmonious style to the whole machine.

- 12" hard chromed special alloy hollow ground knife: longer lasting and easier to sharpen.
- 0 to 9/16" slice thickness.
- Easy to access top mounted, removable all metal knife sharpener with dual action with two stones.
- Slice thickness precision adjustment: gasket-sealed mechanism.
- Drip detecting edge of the gauge plate.
- Bottom enclosure.
- Moisture proof, easy-to-clean ON/OFF switch and knife hub.
- 1/2 HP fan-cooled knife motor with permanently lubricated ball bearings.
- Overload protection manual reset.
- Easy to clean thanks to the round lines.
- Non-slip rubber feet.
- Optional MBR (Manual Blade Removal tool)



**STAINLESS STEEL**

**BLADE COVER & CARRIAGE**

**YOUR PREMIUM HEAVY DUTY WORK MATE**



**ST 12**  
PROFESSIONAL GRAVITY SLICER – MANUAL BELT DRIVEN

Model	Blade	Cutting cross section	Food chute	Chute stroke	Footprint	Overall dimensions	Net weight	Motor
	mm / in	mm / in	mm / in	mm / in	mm / in	mm / in	Kg	Hp
<b>ST 12</b>	300 / 12	240x160 9,44x6,29	250x255 9,84x10,03	330 12,99	A 565/22,24 B 380/14,96 H 470/18,50	A 650/25,59 B 560/22,04 H 470/18,50	29	1/2

Cord & Plug: Attached 5.5 foot exible 3-wire cord with molded plug ts a grounded receptacle. NEMA 5-15  
Voltage: 115 - 60 - 1



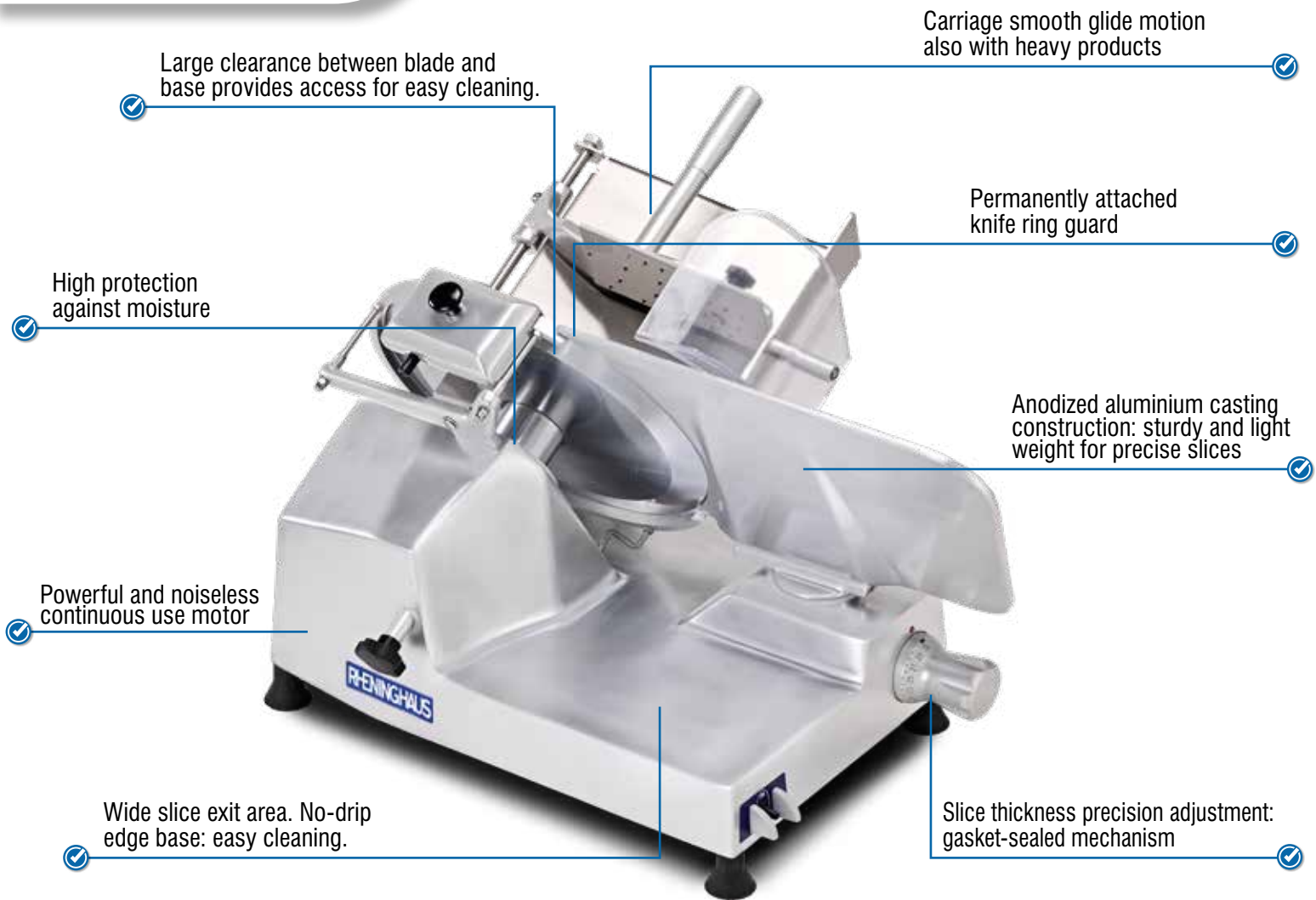

**PRECISION, PERFORMANCE, CONVENIENCE, SUPERIOR CLEANABILITY AND LASTING VALUE**

- The special protections make it suited for humid environments. Ideal for deli shops, supermarkets, restaurants, hotels, catering companies.
- 12" high quality hardened chromium steel alloy blade.
  - 0 to 1/2" slice thickness.
  - Multygrip belt drive: always the right grip.
  - Drip detecting edge of the gauge plate: adjustment mechanism is protected.
  - Stainless steel ball-bearing blade pulley and special moisture-proof gasket.
  - Built-in sharpener, removable for cleaning purposes.
  - 30° carriage angle: good visibility of the slice exit area and better ergonomoy.
  - Non-slip rubber feet.
  - Optional SBR (Safe Blade Removal tool)



STAINLESS STEEL

BLADE COVER & CARRIAGE

YOUR PREMIUM **HEAVY DUTY** WORK MATE



**ST 14**  
PROFESSIONAL GRAVITY SLICER – MANUAL BELT DRIVEN

Model	Blade	Cutting cross section	Food chute	Chute stroke	Footprint	Overall dimensions	Net weight	Motor
	mm / in	mm / in	mm / in	mm / in	mm / in	mm / in	Kg	Hp
<b>ST 14</b>	350 / 14	280x190 11,02x7,48	280x300 11,02x11,81	330 12,99	A 565/22,24 B 380/14,96 H 470/18,50	A 710/27,95 B 600/23,62 H 470/18,50	32	1/2

Cord & Plug: Attached 5.5 foot exible 3-wire cord with molded plug ts a grounded receptacle. NEMA 5-15  
Voltage: 115 - 60 - 1



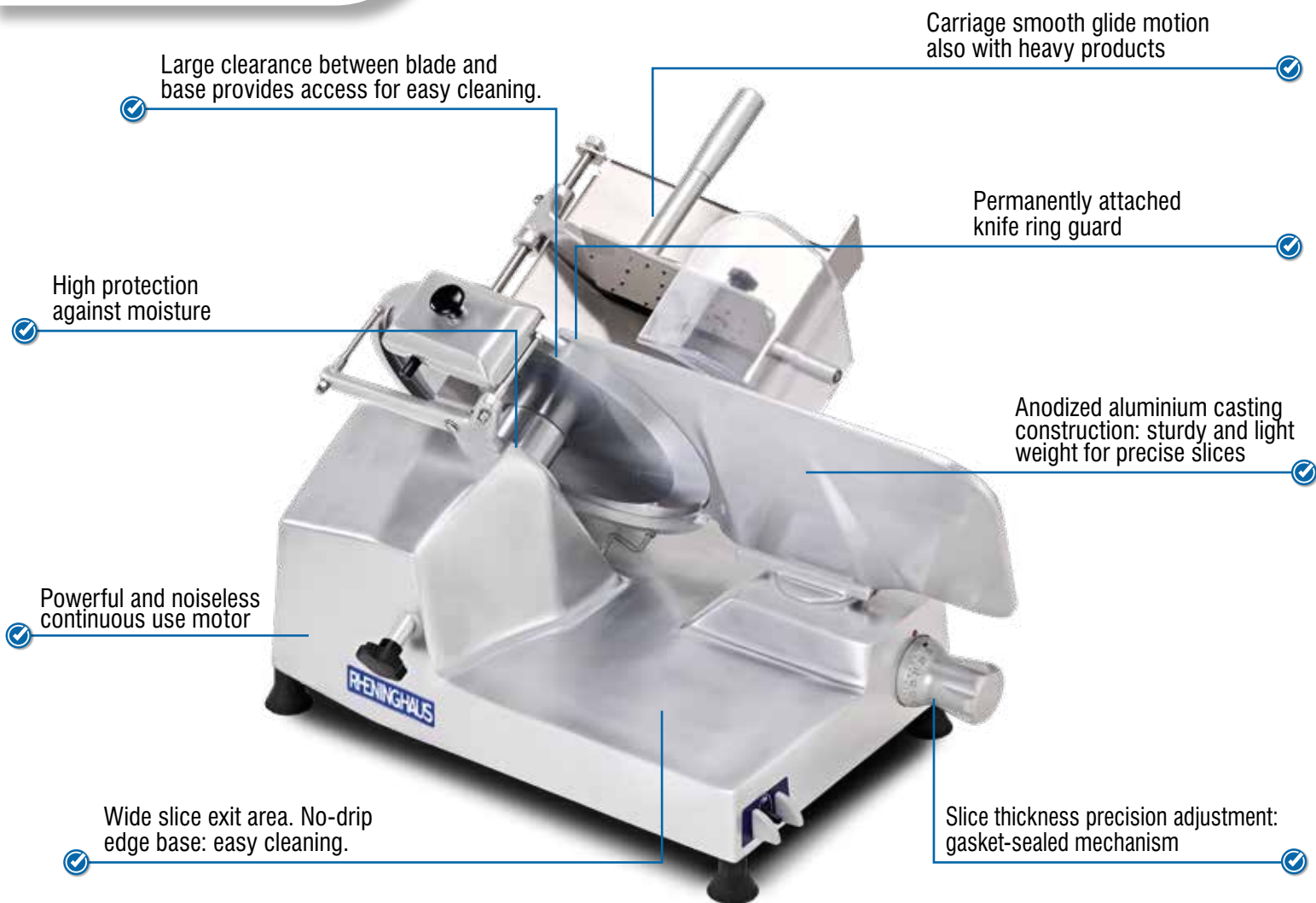

**PRECISION, PERFORMANCE, CONVENIENCE, SUPERIOR CLEANABILITY AND LASTING VALUE**

- The special protections make it suited for humid environments. Ideal for deli shops, supermarkets, restaurants, hotels, catering companies.
- 14" high quality hardened chromium steel alloy blade.
  - 0 to 1/2" slice thickness.
  - Multygrip belt drive: always the right grip.
  - Drip detecting edge of the gauge plate: adjustment mechanism is protected.
  - Stainless steel ball-bearing blade pulley and special moisture-proof gasket.
  - Built-in sharpener, removable for cleaning purposes.
  - 30° carriage angle: good visibility of the slice exit area and better ergonomoy.
  - Non-slip rubber feet.
  - Optional SBR (Safe Blade Removal tool)



STAINLESS STEEL

BLADE COVER & CARRIAGE

YOUR PREMIUM **HEAVY DUTY** WORK MATE



**SST 12**  
PROFESSIONAL GRAVITY SLICER – MANUAL GEAR DRIVEN

Model	Blade	Cutting cross section	Food chute	Chute stroke	Footprint	Overall dimensions	Net weight	Motor
	mm / in	mm / in	mm / in	mm / in	mm / in	mm / in	Kg	Hp
<b>SST 12</b>	300 / 12	240x160 9,44x6,29	250x255 9,84x10,03	330 12,99	A 565/22,24 B 380/14,96 H 470/18,50	A 650/25,59 B 560/22,04 H 470/18,50	29	1/2

Cord & Plug: Attached 5.5 foot exible 3-wire cord with molded plug ts a grounded receptacle. NEMA 5-15  
Voltage: 115 - 60 - 1



Large clearance between blade and base provides access for easy cleaning.

Carriage smooth glide motion also with heavy products

High protection against moisture

Permanently attached knife ring guard

Anodized aluminium casting construction: sturdy and light weight for precise slices

Powerful and noiseless continuous use motor

Wide slice exit area. No-drip edge base: easy cleaning.

Slice thickness precision adjustment: gasket-sealed mechanism

**PRECISION, PERFORMANCE, CONVENIENCE, SUPERIOR CLEANABILITY AND LASTING VALUE**

SST12 is a premium heavy-duty manual slicer.

The SST-Series is a line of premium slicers from Rheninghaus delivering precision, performance, industry-leading convenience, superior cleanability and value.

The special protections make it suitable for humid environments including deli shops, supermarkets, restaurants, hotels, and catering companies.

- 12" high quality hardened chromium steel alloy blade
- 0 to 1/2" slice thickness
- Gear drive: long life, no maintenance
- Carriage-system provides a smooth glide motion suitable for heavy products
- Drip deflecting edge of the gauge plate ensures adjustment mechanism is protected
- Stainless steel ball-bearing blade pulley and special moisture-proof gasket
- Built-in sharpener, removable for cleaning purposes
- 30° ergonomic carriage angle provides good visibility of the slice exit area
- Non-slip rubber feet add stability and grip
- Optional SBR (Safe Blade Removal tool)



Intertek  
4001164



Intertek  
4001164



STAINLESS STEEL

BLADE COVER & CARRIAGE

YOUR PREMIUM **HEAVY DUTY** WORK MATE



**SST 14**  
PROFESSIONAL GRAVITY SLICER – MANUAL GEAR DRIVEN

Model	Blade	Cutting cross section	Food chute	Chute stroke	Footprint	Overall dimensions	Net weight	Motor
	mm / in	mm / in	mm / in	mm / in	mm / in	mm / in	Kg	Hp
<b>SST 14</b>	350 / 14	280x190 11,02x7,48	280x300 11,02x11,81	330 12,99	A 565/22,24 B 380/14,96 H 470/18,50	A 710/27,95 B 600/23,62 H 470/18,50	32	1/2

Cord & Plug: Attached 5.5 foot exible 3-wire cord with molded plug ts a grounded receptacle. NEMA 5-15  
Voltage: 115 - 60 - 1



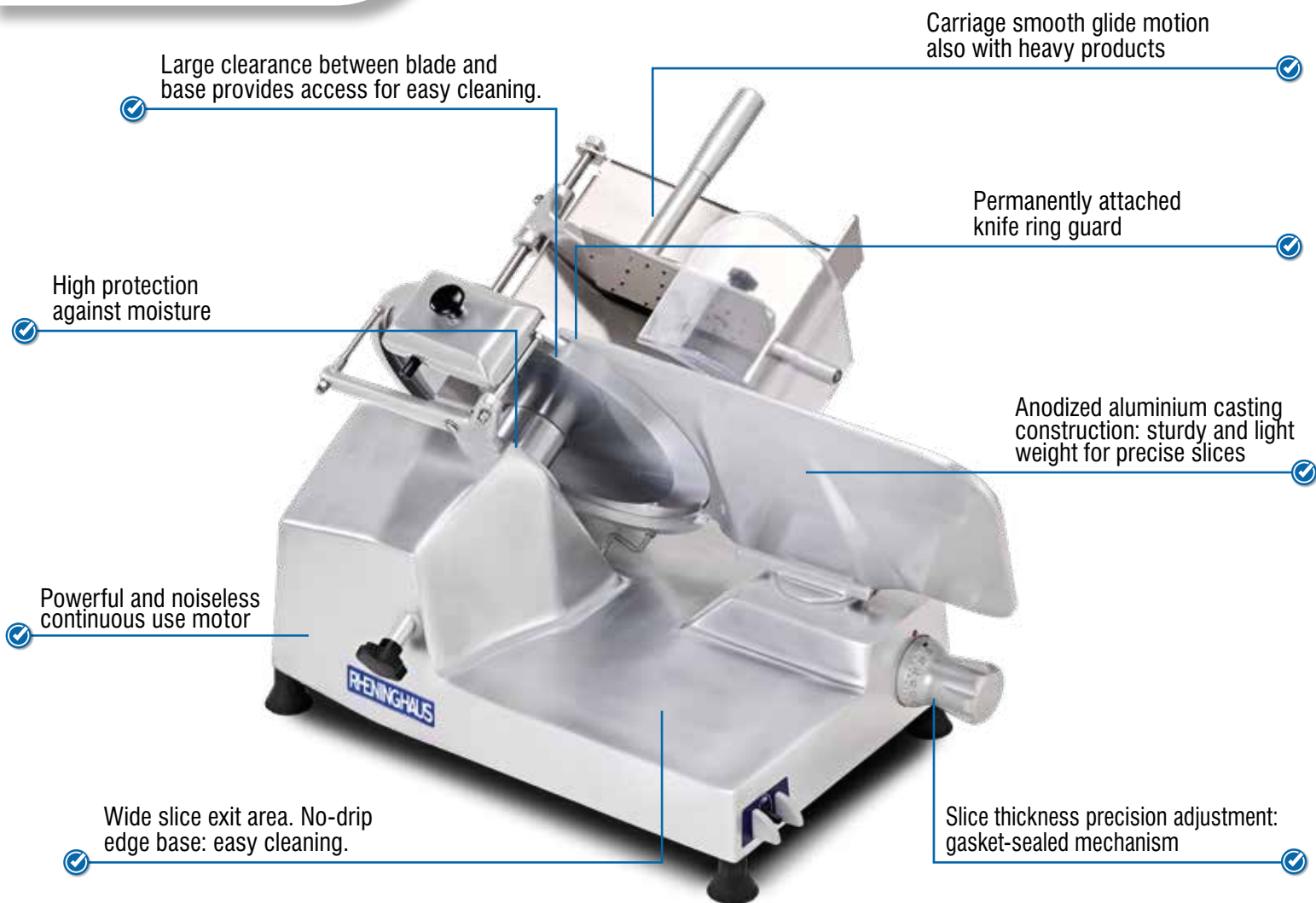

**PRECISION, PERFORMANCE, CONVENIENCE, SUPERIOR CLEANABILITY AND LASTING VALUE**

SST14 is a premium heavy-duty manual slicer. The SST-Series is a line of premium slicers from Rheninghaus delivering precision, performance, industry-leading convenience, superior cleanability and value. The special protections make it suitable for humid environments including deli shops, supermarkets, restaurants, hotels, and catering companies.

- 14" high quality hardened chromium steel alloy blade
- 0 to 1/2" slice thickness
- Gear drive: long life, no maintenance
- Carriage-system provides a smooth glide motion suitable for heavy products
- Drip deflecting edge of the gauge plate ensures adjustment mechanism is protected
- Stainless steel ball-bearing blade pulley and special moisture-proof gasket
- Built-in sharpener, removable for cleaning purposes
- 30° ergonomic carriage angle provides good visibility of the slice exit area
- Non-slip rubber feet add stability and grip
- Optional SBR (Safe Blade Removal tool)



STAINLESS STEEL

BLADE COVER & CARRIAGE

YOUR PREMIUM **HEAVY DUTY** WORK MATE



**STA 12**  
PROFESSIONAL GRAVITY SLICER – AUTOMATIC BELT DRIVEN

Model	Blade	Cutting cross section	Food chute	Chute stroke	Footprint	Overall dimensions	Net weight	Motor
	mm / in	mm / in	mm / in	mm / in	mm / in	mm / in	Kg	Hp
<b>STA 12</b>	300 / 12	285x165 11,22x6,49	300x300 11,81x11,81	330 12,99	A 575/22,63 B 390/15,35 H 595/23,42	A 660/25,98 B 725/28,54 H 595/23,42	43	1/2

Cord & Plug: Attached 5.5 foot exible 3-wire cord with molded plug ts a grounded receptacle. NEMA 5-15  
Voltage: 115 - 60 - 1



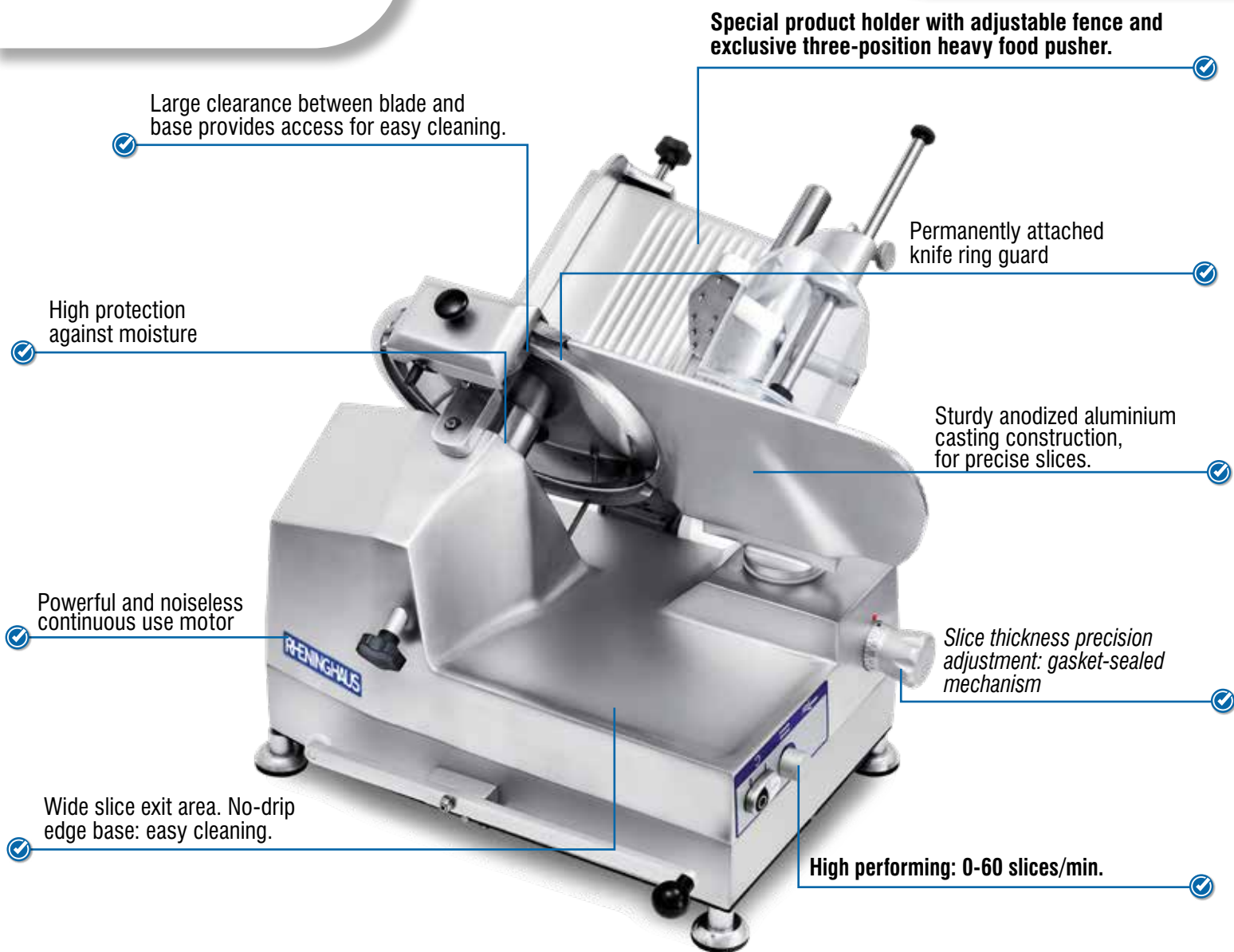

## POWERFUL AUTOMATIC SLICER THAT CAN ALSO BE USED MANUALLY

Ideal for supermarkets, restaurants, catering companies, laboratories.

- 12" high quality hardened chromium steel alloy blade.
- Insulated switch with manual reset provides overload protection
- 0 to 1/2" slice thickness.
- Multygrip belt drive: always the right grip.
- Drip detecting edge of the gauge plate: adjustment mechanism is protected.
- Stainless steel ball-bearing blade pulley and special moisture-proof gasket.
- Built-in sharpener, removable for cleaning purposes: simple and convenient.
- 30° carriage angle: good visibility of the slice exit area and better ergonomoy.
- Optional SBR (Safe Blade Removal tool)



BELT DRIVEN

LARGE CUT CAPACITY

YOUR PREMIUM **HEAVY DUTY** WORK MATE



## MO 12

PROFESSIONAL GRAVITY SLICER – MANUAL BELT DRIVEN

Model	Blade	Cutting cross section	Food chute	Chute stroke	Footprint	Overall dimensions	Net weight	Motor
	mm / in	mm / in	mm / in	mm / in	mm / in	mm / in	Kg	Hp
<b>MO 12</b>	300 / 12	290x140 11,41x5,51	280x300 11x12	315 12,40	A 540/21,25 B 360/14,17 H 460/18,11	A 650/25,59 B 540/21,25 H 460/18,11	30	1/2

Cord & Plug: Attached 5.5 foot exible 3-wire cord with molded plug ts a grounded receptacle. NEMA 5-15  
Voltage: 115 - 60 - 1



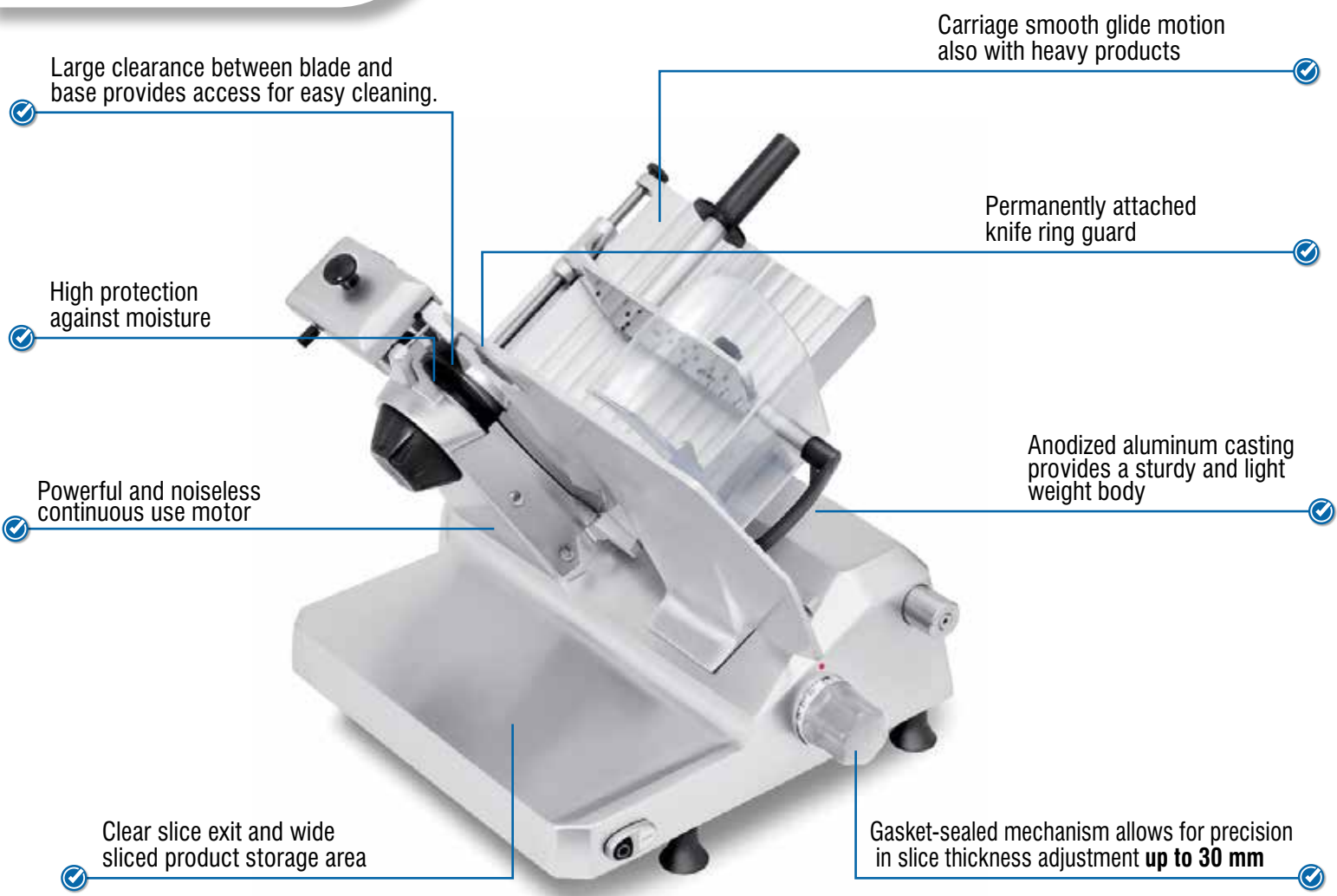

**IDEAL MACHINE FOR DELICATESSEN, SUPERMARKETS AND LARGE SIZE KITCHENS**

- M012 is a premium heavy-duty manual slicer with clear slice exit design as the entire area behind the blade is completely free. This slicer offers larger cut capacity, exact thickness regulation and smooth carriage stroke.
- 12" high quality hardened chromium steel alloy blade
  - Insulated switch with manual reset provides overload protection
  - Multi-grip drive belt: always the right grip
  - Stainless steel food pusher toothed plate, removable for cleaning purposes
  - Optional SBR (Safe Blade Removal tool)
  - Stainless steel ball-bearing blade pulley and special moisture-proof gasket
  - Built-in sharpener, removable for cleaning purposes
  - 30° ergonomic carriage angle provides good visibility of the slice exit area
  - Non-slip rubber feet add stability and grip



BELT DRIVEN

LARGE CUT CAPACITY

YOUR PREMIUM **HEAVY DUTY** WORK MATE



**MO 14**

PROFESSIONAL GRAVITY SLICER – MANUAL BELT DRIVEN

Model	Blade	Cutting cross section	Food chute	Chute stroke	Footprint	Overall dimensions	Net weight	Motor
	mm / in	mm / in	mm / in	mm / in	mm / in	mm / in	Kg	Hp
<b>MO 14</b>	350 / 14	290x190 11,41x7,48	280x300 11x12	315 12,40	A 540/21,25 B 360/14,17 H 500/19,68	A 700/27,55 B 540/21,25 H 500/19,68	33	1/2

Cord & Plug: Attached 5.5 foot exible 3-wire cord with molded plug ts a grounded receptacle. NEMA 5-15  
Voltage: 115 - 60 - 1



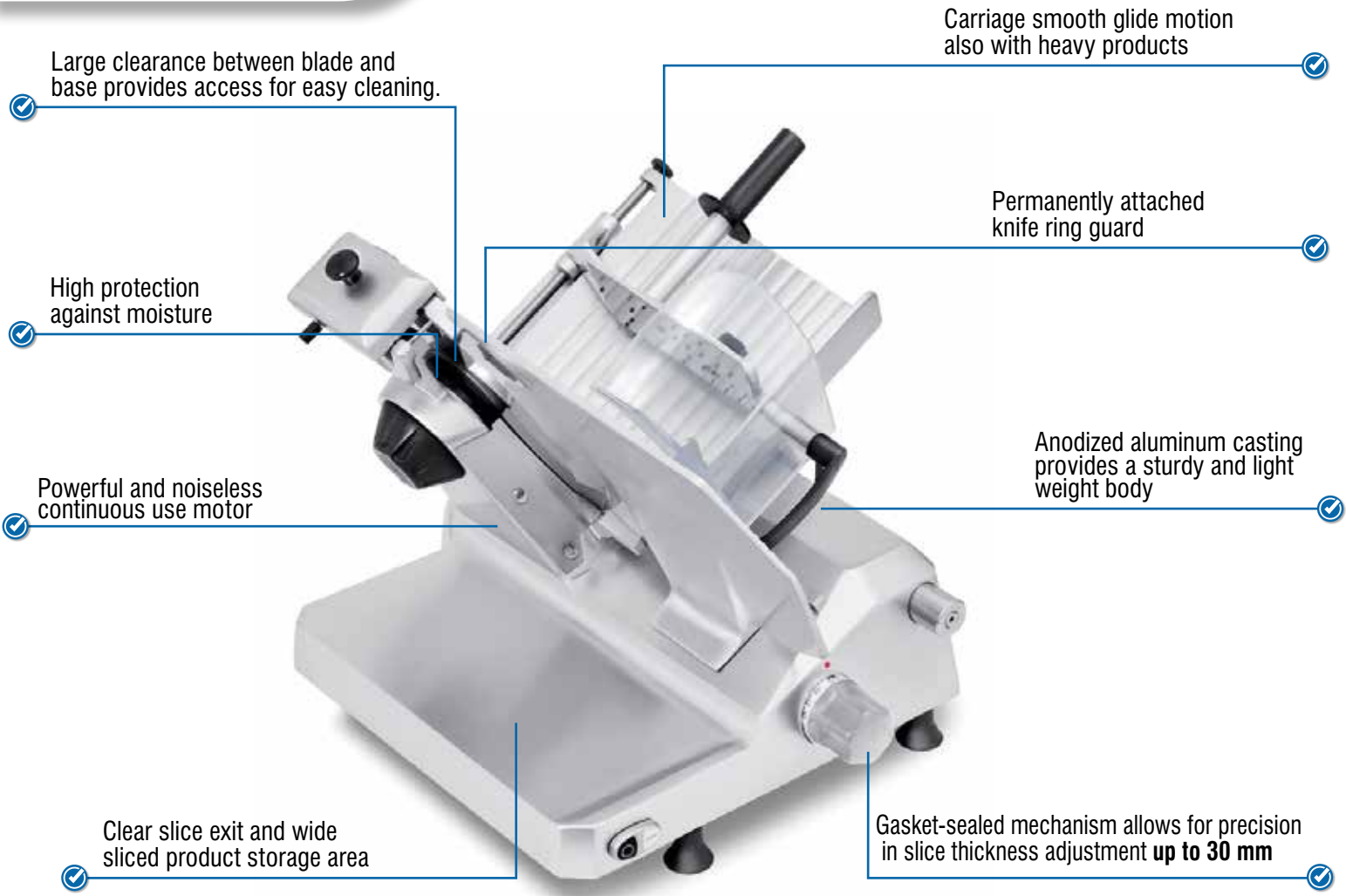

**IDEAL MACHINE FOR DELICATESSEN, SUPERMARKETS AND LARGE SIZE KITCHENS**

M014 is a premium heavy-duty manual slicer with clear slice exit design as the entire area behind the blade is completely free. This slicer offers larger cut capacity, exact thickness regulation and smooth carriage stroke.

- 14" high quality hardened chromium steel alloy blade
- Insulated switch with manual reset provides overload protection
- Multi-grip drive belt: always the right grip
- Stainless steel food pusher toothed plate, removable for cleaning purposes
- Optional SBR (Safe Blade Removal tool)
- Stainless steel ball-bearing blade pulley and special moisture-proof gasket
- Built-in sharpener, removable for cleaning purposes
- 30° ergonomic carriage angle provides good visibility of the slice exit area
- Non-slip rubber feet add stability and grip

# FOOD PREPARATION



*Selection of catering and butcher machines, designed to optimize work and guarantee high-quality results. This range of equipment includes vacuum packaging and cooking machines, vegetable cutters, cutters, immersion blenders, mincers and bone saws. They are all made with robust materials and innovative technologies. Our machines are ideal for meeting the needs of restaurants, butchers and catering businesses, ensuring efficiency, safety and ease of use.*





# WINDSHEAR 31

Vertical compact vacuum packaging machine ideal for liquids, granulates and powders best for bars or as a second machine.

Max bag size 300x350 mm which can easily hold 3 Lt

Lid without pistons









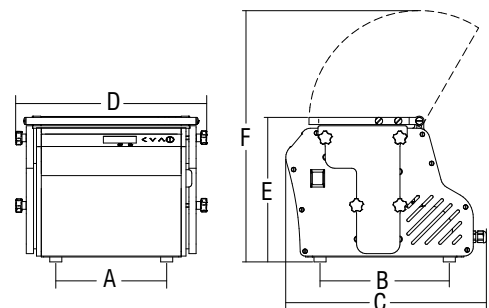





Practical niches on the profile to move the unit

Extraordinary patented solution for internal cleaning:

- Transparent sides of the tank offer perfect visibility inside the tank

- Side panels can be easily and completely disassembled without tools for easy and thorough cleaning inside the tank



														
	kw	lph	mc/h	mm	mm	mm	mm	mm	mm	mm	mm	kg	mm	kg
<b>WINDSHEAR 31</b>	0.15	1ph	4	310	326x60 h.250	230	268	416	396	300	521	22	515x435x385	24



# BREEZE M 31 M mc 8 - 41 M mc 20

- Great volume transparent lid*
- Easily removable sealing bar*
- Manual controls with fast and intuitive adjustment of vacuum and sealing time*
- Extremely easy to clean thanks to the flatness of the chamber. Automatic lifting the lid by means of pneumatic pistons.*
- Support for vacuum bags with liquids*
- Analogic vacuum gauge*



**BREEZE 31 M mc 8**



**BREEZE 41 M mc 20**

OPTIONALS



+ External suction hose



+ Containers GN 1/1 - 1/2 (h.100/150) with s/steel cover









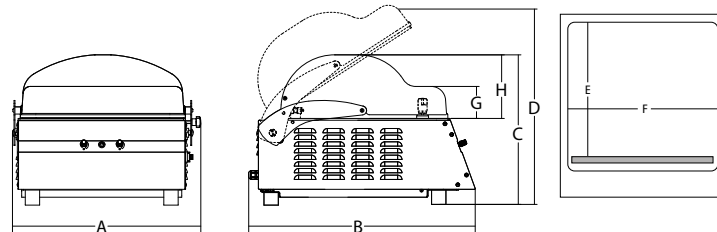







0-100% vacuum



+ Containers GN 1/1 - 1/2 - 1/3 (h.100/150) with cover in Tritan

0-80% vacuum



																
	kw	lph	mc/h	mm	mm	mm	mm	mm	mm	mm	mm	mm	mm	kg	mm	kg
<b>BREEZE 31 M mc 8</b>	0.35	1ph	8	310	340x360 h.185	433	571	404	523	334	340	95	170	36	720x570x770	48
<b>BREEZE 41 M mc 20</b>	0.75	1ph	20	410	430x410 h.195	525	631	417	544	390	430	95	180	54	760x640x770	66



# BREEZE 31 mc 8 - 41 mc 12 - 41 mc 20

The extraordinary design reduces the footprint of the machine and improves practicality. Great volume chamber with lid made of injected Tritan®. Easily removable sealing bar. Extremely easy to clean thanks to the perfect flatness of the product support surface made of 5mm thick AISI 304 stainless steel. Automatic lid lifting by means of pneumatic pistons. Support for bags with liquid.



**BREEZE 31 mc 8**



**BREEZE 41 mc 12**

## OPTIONALS



+ Plexiglass support



+ External suction hose



+ Containers GN 1/1 - 1/2 (h.100/150) with s/steel cover









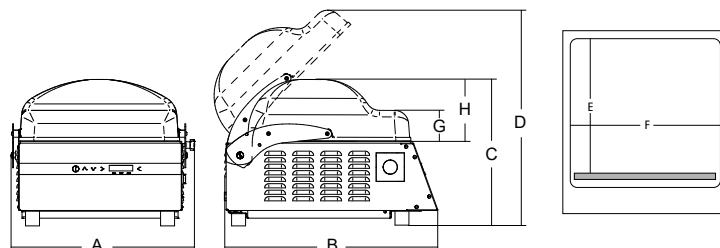







0-100% vacuum



+ Containers GN 1/1 - 1/3 (h.100/150) with cover in Tritan

0-80% vacuum



																
	kw	lph	mc/h	mm	mm	mm	mm	mm	mm	mm	mm	mm	mm	kg	mm	kg
<b>BREEZE 31 mc 8</b>	0.35	1ph	8	310	340x360 h.160	402	525	408	587	334	340	95	170	38	720x570x770	48
<b>BREEZE 41 mc 12</b>	0.45	1ph	12	410	430x410 h.170	493	585	422	630	390	430	99	180	54	760x640x770	64
<b>BREEZE 41 mc 20</b>	0.75	1ph	20	410	430x410 h.170	493	585	422	630	390	430	99	180	56	760x640x770	66



# GHIBLI

31 mc 8 P - 41 mc 20 P - 51 mc 20 P - 41x2 mc 20 P

The extraordinary design reduces the footprint of the machine and improves ergonomics and usability. Great volume lids are made of thermoformed plexiglass on mod. 51 and 41x2, while on mod. 31 and 41 are made of injected Tritan®.

Easily removable sealing bar.

Extremely easy to clean thanks to the flatness of the product tray, made of AISI 304 stainless steel 5 mm thick.

Lid lifts up automatically with pneumatic pistons.

Including taper support for bags with liquid.



GHIBLI 31 mc 8 P



GHIBLI 41 mc 20 P



GHIBLI 51 mc 20 P



GHIBLI 41x2 mc 20 P



✔ Built in thermal label printer to fix date, time and packing specifications on every single bag (standard)

**OPZIONI/OPTIONS**



+ External suction hose



+ Gas flush system option (MAP)



+ **SanO3** - integrated and automated sanitizing system with Ozone



+ **A.O.R.** - Automatic Oil Replacement



+ Plexiglass support









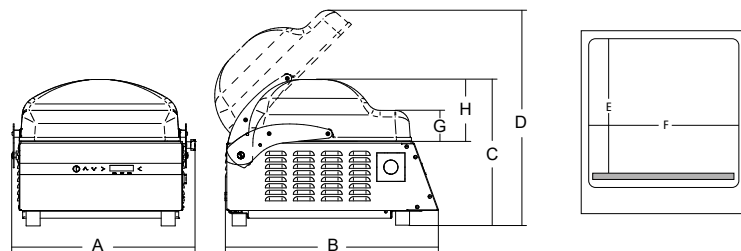









+ Containers GN 1/1 - 1/2 (h.100/150) with s/steel cover  
0-100% vacuum



+ Containers GN 1/1 - 1/2 - 1/3 (h.100/150) with cover in Tritan  
0-80% vacuum



																
	kw	lph	mc/h	mm	mm	mm	mm	mm	mm	mm	mm	mm	mm	kg	mm	kg
<b>GHIBLI 31 mc 8 P</b>	0.35	1ph	8	310	340x360 h.130	402	525	360	480	333,4	340	85	140	46	720x570x770	57
<b>GHIBLI 41 mc 20 P</b>	0.75	1ph	20	410	430x410 h.140	493	585	370	542	390	430	85	150	56	760x640x770	67
<b>GHIBLI 51 mc 20 P</b>	0.75	1ph	20	510	540x430 h.190	609	640	420	605	430	540	90	200	70	840x870x750	84
<b>GHIBLI 41x2 mc 20 P</b>	0.75	1ph	20	410x2	545x460 h.190	609	640	420	605	424	428	90	200	71	840x870x750	85



# SAT SYSTEM

WINDSHEAR SAT - GHIBLI 30 SAT - GHIBLI 40 SAT - GHIBLI 40x2 SAT

Sat System is an optional function that allows you to quickly connect a second satellite machine to the main machine to be used instead of or simultaneously with the main machine.

With a small investment, you can thus double productivity as if you had two machines available or you can have a satellite machine specifically dedicated to liquid or powdery products (Windshear SAT).

Ideal for:

- all health and hygiene situations where the use of different machines for different products is required.
- those who want to be faster in preparing their vacuum workload
- those who want to exploit the maximum capacity of the bags with liquid products (using Windshear SAT)





It is recommended to use satellite units of the same size as the main machine or smaller

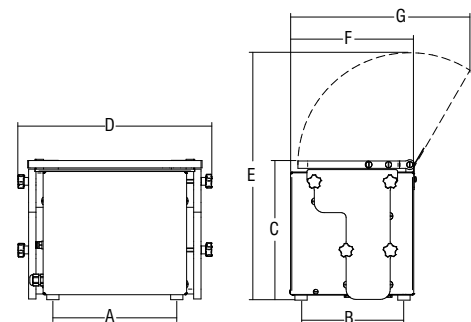

GHIBLI 41 mc 20 P MASTER

WINDSHEAR SAT







		A	B	C	D	E	F	G			
	mm	mm	mm	mm	mm	mm	mm	mm	kg	mm	kg
WINDSHEAR SAT	310	253	210	284	396	505	252	366	13	-	-

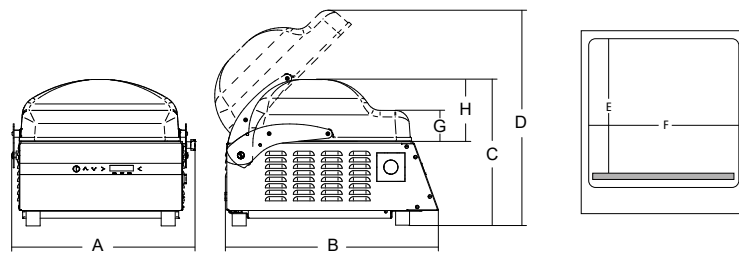

**Ghibli 41 mc 20 P MASTER**

**Ghibli 30 SAT**



		<b>A</b>	<b>B</b>	<b>C</b>	<b>D</b>	<b>E</b>	<b>F</b>	<b>G</b>	<b>H</b>			
	mm	mm	mm	mm	mm	mm	mm	mm	mm	kg	mm	kg
<b>Ghibli 30 SAT</b>	310	402	525	408	587	334	340	95	170	24	720x570x770	34
<b>Ghibli 40 SAT</b>	410	493	585	422	630	390	430	99	180	31	760x640x770	41
<b>Ghibli 40x2 SAT</b>	410x2	609	640	420	605	424	428	90	210	45	840x870x750	55



# SV 2K

## Sous vide cooking system

High precision warmer with temperature control. Working temperature display. 25 storable programs.

Programmable postponed departure. IPX3 protection rated stainless steel structure.

Can be applied to the container by means of a clamp. (max depth 16,5 cm). Protection device switches off the warmer in case of accidental use without liquid. Circulating pump to help the best product mixing. Temperature sensor to prevent overheating.



### OPZIONI/OPTIONALS

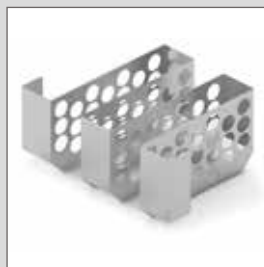

+ Vacuum bags divider









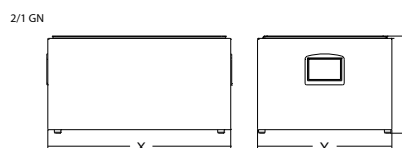
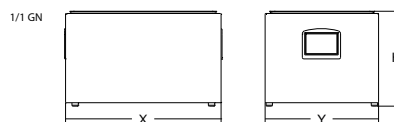
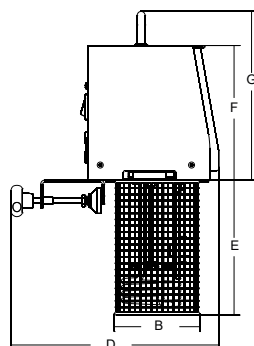
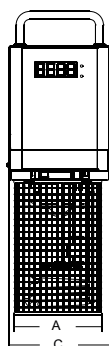







+ 1/1 GN s/steel container with lid



+ 2/1 GN s/steel container with lid



															
	watt	ph	°C	lt	lt	mm	mm	mm	mm	mm	mm	mm	kg	mm	kg
<b>SV 2K</b>	2.000	1ph	24÷99	-	-	110	105	130	260	170	170	210	4.5	330x455x240	5.5
<b>1/1 GN</b>	-	-	-	27	22	565	360	230	-	-	-	-	7.7	720x500x350	11.5
<b>2/1 GN</b>	-	-	-	57.5	43	650	530	230	-	-	-	-	13	750x650x400	16



# SV 2K NFC WiFi









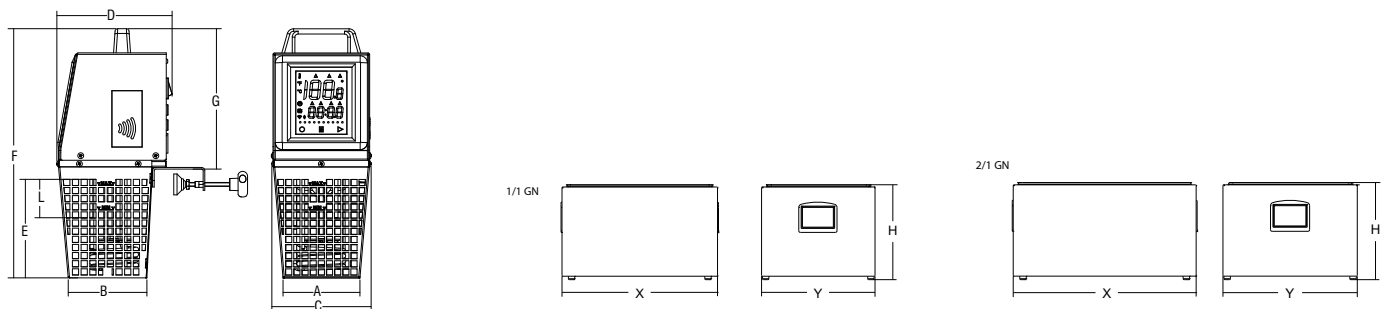







The NFC versions fitted with a built-in aerial to get on-the-spot readings from the SWP "Softcooker Wireless Probes"  
 A large and practical 5" touch screen display, with IP 67 rating  
 Up to 10 instant programmes on the machine and countless other programmes through the APP.  
 Practical handle for carrying the machine  
 Via the special free App, the Wi-Fi connection allows you to check the cooking even from home.  
 The APP also allows you to manage various pieces of equipment, private and public recipes with 4 levels, HACCP cooking logs, printing of adhesive labels, setting audible alarms, Multitimer function, reading and configuration of the SWP "Softcooker Wireless Probes" and a whole lot more.



## SWP Wireless probes NFC

Practical and efficient system for monitoring the temperature in the heart of vacuum-cooked food  
 Practical and robust wireless probes with NFC technology which allows you to read the temperature in the middle using a practical APP or directly via Softcooker Wi-Food NFC  
 Can be reused thousands of times and loaded with data regarding the product, supplier, cooking, packaging date etc.  
 Free, easy and intuitive management APP



																
	watt	lph	°C	lt	lt	mm	mm	mm	mm	mm	mm	mm	mm	kg	mm	kg
<b>SV 2K</b>	2.000	1ph	24÷99	-	-	118	120	152	176	151	382	215	52	5	330x455x240	5.5
<b>1/1 GN</b>	-	-	-	27	22	565	360	230	-	-	-	-	-	7.7	720x500x350	11.5
<b>2/1 GN</b>	-	-	-	57.5	43	650	530	230	-	-	-	-	-	13	750x650x400	16



## 10 Basic Rules for the slicers

**First of all: always keep these important golden rules in mind!**

- ✓ **1. Read operating instructions before using machine**
- ✓ **2. Clean the slicer at least once a day**
- ✓ **3. Sharpen the blade at least once a week**
- ✓ **4. Lubricate sliding bars at least once a month**
- ✓ **5. Keep out of children**
- ✓ **6. Do not turn machine on unless all guards are in place**
- ✓ **7. Do not feed food by hand: always use food pusher**
- ✓ **8. Always electrically ground the machine**
- ✓ **9. Always unplug machine before cleaning**
- ✓ **10. Keep machine away from water: avoid water jets during cleaning**

### How to improve the sliding of the food chute

Unplug the power cord, clean the slide rod, being careful not to damage the electrical parts, then lubricate with vaseline oil.

### How to improve the sliding of the end weight

Carefully clean the end weight slide rod the food chute runs along, then lubricate with vaseline oil.

**FOOD  SERVICE**  
**S·O·L·U·T·I·O·N·S**  
[www.foodservicesolutions.com](http://www.foodservicesolutions.com)

© 2026 Copyright Rheninghaus

Image rights belong to Rheninghaus.  
 Reproduction of photos and text, even partial, is prohibited.

Technical data and specifications are subject to change without notice.

VER. 2026





[www.italianslicers.com](http://www.italianslicers.com)